



Allukemi Sky™ Self-supporting

Table of Contents.

<p>1. Introduction Page 3</p> <p> 1.1 From the designer to the consumer</p> <p>2. Important warnings Page 4</p> <p>3. Technical information Page 5</p> <p> 3.1 Product description</p> <p> 3.2 Functional diagram</p> <p> 3.3 Upright/handrail components</p> <p> 3.4 Beam components</p> <p> 3.5 Toe-clip board components</p> <p> 3.6 System</p> <p> 3.7 Description of components</p> <p>5. Assembly Page 19</p> <p> 4.1 Recommendations</p> <p> 4.2 Assemblers</p> <p> 4.3 Assembly kit</p> <p> 4.4 Movement and storage</p> <p> 4.5 Stages</p> <p>6. Guarantees Page 27</p> <p> 6.1 Duration</p> <p> 6.2 Exclusion</p> <p> 6.3 Limitations</p> <p> 6.4 Responsibilities</p> <p> 6.5 Renewal</p> <p> 6.6 Testing and maintenance</p> <p> 6.7 Jurisdiction</p>	<p>7. References Page 15</p> <p> 7.1 Manufacturer's Instructions</p> <p> 7.2 Regulations</p> <p> 7.2.1 Technical standards</p> <p> 7.2.2 National regulations</p> <p> 7.2.3 Local regulations</p> <p> 7.3 Internet Sites</p> <p>8. Manufacturer and Distributor Page 16</p> <p> 8.1 Manufacturer</p> <p> 8.2 Distributor</p>
---	--

1. Introduction.

Preventive and protective measures should be installed for works performed in places exposed to a danger of falls, in order to allow the operator to perform maintenance operations to move easily along the work area.

These protective devices, in addition to being safe, must be ergonomic, or rather “comfortable” to use for the operator, and they must be provided in the Technical Coverage Report (ETC) that is drawn up by the Health & Safety Coordinator at the design phase (CSP), in agreement with the designer, and be an integral part of the project both of the technical dossier and of the works. The ETC is therefore composed of various documents, with relevance to different subjects, in particular:

- **Coordinator/technician:** graphics with routes and access points to the roofing highlighted, technical report with adopted design solutions, structure support and mounting calculation report.
- **Manufacturer:** product certification, Manufacturer Instructions - Manual of installation, use and maintenance.
- **Installer:** declaration of conformity of the works performed.

From the designer to the consumer 1.1

With regard to the points mentioned above, the objectives of **Genesi Italia** are to create a direct line between the designer of the system and the final user, passing by the manufacturer and installer by means of:

- Study of the line through software with immediately understandable graphical interface and return of the elements that constitute the system (as an alternative to consultancy from our technical office).
- Supply of the elements provided for the entire system directly from **Genesi Italia** or from the chain of Partners and authorised resellers.
- Installation with simple procedures according to the Installation Manual by installers trained by Genesi Italia (subject of this document).
- Provision of information necessary for the proper use and maintenance contained in the Manufacturer's Instructions.

2. Important warnings.

- Before system use, read the Manufacturer's Instructions - Use and Maintenance.
- All users must be trained and informed about risks and must have carried out the training on 3rd category PPE.
- Users must be in optimal physical conditions for the duration of works.
- Operators must be trained and informed about emergency, recovery and evacuation procedures in the work area in which they operate.
- Making changes and/or additions to the equipment/system without consent from the manufacturer/distributor is prohibited.
- Equipment must not be used beyond its limitations or for purposes other than those foreseen.
- Before using the system, verify good equipment conditions as much as possible.
- For safety, it is imperative that use of equipment be suspended immediately in the event of doubts about their safe conditions or if they have been used for fall arrest. In both cases, before restarting operation, you must get written confirmation from a competent person stating that re-use of the system is acceptable.
- Periodic system review is mandatory.
Verify maintenance with the holder of the Technical File.

3. Technical information.

Product description

3.1

Allukemi Sky® Self-supporting railings are in compliance with standard EN ISO 14122-3 which includes permanent access safety devices to machinery with ladders, stepladders and guard railings. The standard also applies to ladders, stepladders and guard railings in the part of the building in which maintenance of said machinery must be performed, provided that the main function of said part of the building is to supply a means of access to the maintenance site. It is a collective protection system, so there is a maximum number of operators that can simultaneously access the area protected with railings. The only constraint is that the area not be accessible to the public but only to maintenance personnel.

Allukemi Sky® Self-supporting railings do not need to be mounted in any way to the structure and integrate into the roof, thanks to layers of SBR rubber interposed between the structure and the railing elements. Required resistance to overturning and displacement is obtained with a 25 Kg concrete counter-weight engaged into the base with a horizontal arm. Application is possible whenever the zone to be protected has a perimeter plenum, as it can integrate perfectly into the existing structure, so as to bring the height of the protection to 110 cm from the floor level as provided by law. In the event that the plenum is absent, the railing must be positioned at at least 1.5 m (upon assessment by the Genesi Italia Technical Department) from the edge of the building and must be completed with a toe-clip board. It is composed of uprights set every 150 cm, engaged onto a base together with a horizontal lever arm on which the concrete block is mounted.

The handrail is mounted on the top of the uprights and a

strut is also inserted in the middle. The footprint of the plan, including the block, is 120 cm. Straight or inclined uprights can be constructed. Railings are available in the following configurations:

SKAD: Straight Allukemi Sky™ Self-supporting

SKAI: Inclined Allukemi Sky™ Self-supporting

Users must be in optimal physical conditions for the duration of works.

Before use, verify the presence of recovery and rescue floors or procedures in the plant location to be implemented in case of need.

The plant is guaranteed for 10 years with no annual maintenance requirement.

All components are made of aluminium with the possibility of coating with epoxy paint as a base and any desired RAL colour paint.

The railings in question have been tested by the Apave Certifying Organisation and the elements used at times are in accordance with those tested.

Below is a detailed description of the system.

Functional diagram

3.2

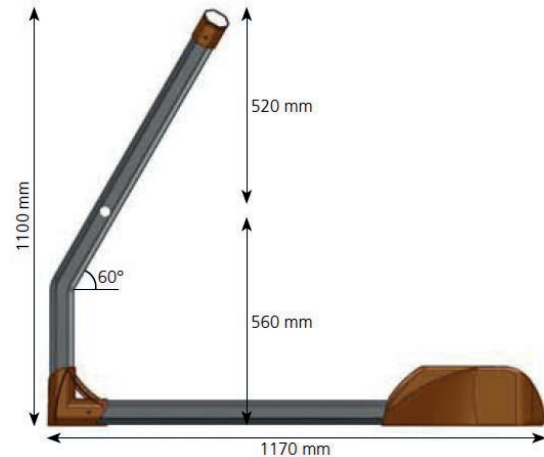
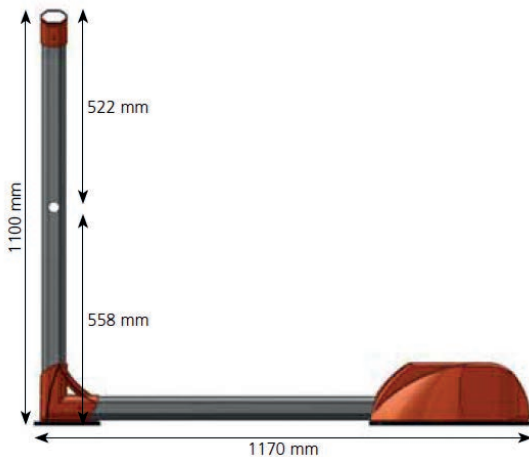

Upright/handrail components

3.3

Uprights are mounted at a distance of 150 cm for all types. The elements that characterise them include:

- self-supporting base art. SKA
- SBR rubber for base art. SKAN
- concrete counter-weight art. SKB
- SBR rubber for counter-weight art. SKBN
- polygonal extrusion art. SK01 to be used for straight or inclined uprights, for handrails and for horizontal lever arms
- polygonal joint art. SK02
- horizontal polygonal corner transmission art. SK03
- vertical polygonal corner transmission art. SK04
- horizontal polygonal joint art. SK05
- polygonal T-fitting, art. SK06
- polygonal L-fitting, art. SK07
- polygonal cap art. SK09
- polygonal cap for fastening art. SK10

Beam components

3.4

Beams are mounted when the plenum is absent or less than 60 cm. The elements that characterise them include:

- round extrusion art. SK11
- round joint art. SK12
- round corner transmission art. SK13
- round cap for fastening art. SK14
- round cap art. SK15

Toe-clip board components

3.5

- toe-clip board support art. SK17
- toe-clip board joint art. SK18

System

3.6

Other elements used in addition to specific railing components used for closing the system and its identification:

- mandatory sign art. CA00 in the vicinity of every access point
- identifier seal art. C35

Description of components 3.7

Self-supporting base art. SKA

Used as the support foot of the vertical upright and as a connecting component with the counter-weight arm. Equipped with an SBR rubber anti-slip base and with grub screws for locking and adjusting the vertical upright. In addition, a toe-clip board can be applied if necessary on the front part of the base.



Material:

aluminium die-cast, alloy EN AB 46100

Geometry:

see figure

Weight:

0.38 kg

Equipment:

3 threaded holes with M6x10 mm flat grubs, 2 front for upright polygonal extrusion and lever arm mounting and 1 rear for upright mounting.

SBR rubber for base art. SKAN

SBR rubber for self-supporting bases are to be interposed between the bases themselves and the structure to prevent direct contact which could cause wear on the waterproofing of the latter.



Material:

SBR rubber

Geometry:

same geometry as the universal base

Concrete counter-weight art. SKB

Concrete counter-weights are connected to the end part of each horizontal lever arm to prevent overturning and railing movement.



Material:

Concrete

Geometry:

see figure

Weight:

25 Kg

Mounting:

1 6.3x90 mm self-tapping screw

Equipment

1 Ø 6.5 hole for mounting the counter-weight to the lever arm

SBR rubber for counter-weight art. SKBN

SBR rubber for concrete counter-weights are to be interposed between the element and the structure to prevent direct contact which could cause wear on the waterproofing of the latter.



Material:

SBR rubber

Geometry:

same geometry as the counter-weight

Polygonal extrusion art. SK01

Polygonal extrusions are used for uprights, for horizontal lever arms and for handrails.



Material:

aluminium alloy 6060-T6

Geometry:

maximum dimensions 65x30 mm and thickness 2.5 mm, straight or inclined, cut to size (h = 104 cm) when used as an upright

in 3/6 m rods if used as a handrail

Net weight:

1.00 Kg/m

Mounting:

with M6x10 flat grub screws at bases with 4.2x16 mm self-tapping screws for transmission corners, joints and fittings

Equipment

when used as an upright, a Ø 31 hole is present to allow round profile passage of the cross beam

Polygonal joint art. SK02

Polygonal joints are used to restore polygonal extrusion continuity when used as a handrail.



Material:

aluminium alloy 6060-T6

Geometry:

maximum dimensions 58x23 mm and thickness 2mm
L=150 mm

Net weight:

0.090 Kg

Mounting:

2 4.2x19 mm countersunk screws, with Ø 4 countersunk drilling in the lower part of the two handrail sections to be connected

Vertical polygonal corner transmission art. SK03

Horizontal polygonal corner transmissions are used to connect the two consecutive handrail sections and allow for a change of horizontal direction.



Material:

aluminium die-cast, alloy EN AB 46100

Geometry:

see figure

Net weight:

0.67 Kg

Mounting:

2 4.2x19 mm self-tapping screws for each handrail attachment side

Equipment:

4 Ø 4mm countersunk holes, 2 bottom and 2 top

Vertical polygonal corner transmission art. SK04

Vertical polygonal corner transmissions are used to connect the two consecutive handrail sections and allow for overcoming irregular levels.



Material:

aluminium die-cast, alloy EN AB 43100

Geometry:

see figure

Net weight:

0.34 Kg

Mounting:

2 4.2x19mm self-tapping screws

Equipment:

2 Ø 4mm countersunk holes at the bottom

Horizontal polygonal joint art. SK05

Horizontal polygonal joints are used to connect two consecutive handrail sections and allow for a change of horizontal direction with inclined uprights.



Material:

aluminium die-cast, alloy EN AB 46100

Geometry:

see figure

Net weight:

0.67 Kg

Mounting:

2 4.2x19mm self-tapping screws

Equipment

2 Ø 4mm countersunk holes at the bottom

Polygonal T-fitting art. SK06

Polygonal T-fittings are used to connect middle uprights with the handrail.



Material:

aluminium die-cast, alloy EN AB 46100

Geometry:

see figure

Net weight:

0.28 Kg

Mounting:

2 4.2x16mm self-tapping screws on the handrail

2 4.2x16mm self-tapping screws on the upright

Equipment:

4 Ø 4mm countersunk holes (2 on the vertical part, 2 at the bottom)

Polygonal L-fitting art. SK07

Polygonal L-fittings are used to connect end uprights with the handrail.



Material:

aluminium alloy EN AB 46100

Geometry:

see figure

Net weight:

0.21 Kg

Mounting:

1 4.2x19mm self-tapping screw on the handrail

1 4.2x19mm self-tapping screw on the upright

Equipment:

2 Ø 4mm holes (1 on the vertical part, 1 on the bottom)

Polygonal cap art. SK09

Polygonal caps are used to close the end of the handrail.



Material:

aluminium alloy 6060-T6

Geometry:

maximum dimensions 58x23 mm and thickness 2 mm

L=30 mm with closing plate with maximum dimensions

65x30 mm

Net weight:

0.030 Kg

Mounting:

1 4.2x19 mm countersunk screws, with Ø 4 countersunk drilling in the lower part of the handrail

Polygonal cap for fastening art. SK10

Polygonal caps for mounting are used to fasten the end of the handrail to the wall.



Material:

aluminium alloy 6060-T6

Geometry:

maximum dimensions 58x23 mm and thickness 2 mm
L=30 mm with closing plate with maximum dimensions 120x70 mm

Net weight:

0.074 Kg

Mounting:

2 Ø 12mm mechanical wall anchors
1 4.2x19 mm countersunk screws, with Ø 4 countersunk drilling in the lower part of the handrail

Equipment

2 Ø 13 holes with wheelbase 90 mm

Round extrusion art. SK11

Round extrusions are used to make the cross beam when the plenum is less than 60 cm.

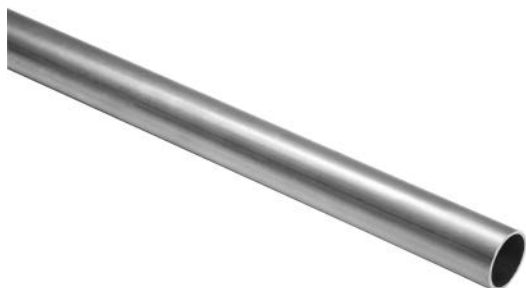

Material:

aluminium alloy 6060-T6

Geometry:

round Ø 30 mm and thickness 2 mm in 3/6 m rods

Net weight:

0.68 Kg/m

Mounting:

1 4.2x30 mm countersunk screws, with Ø 4 countersunk drilling at each upright

Round joint art. SK12

Round joints are used to restore round extrusion continuity of the cross beam.



Material:
aluminium alloy 6060-T6

Geometry:
round \varnothing 25 mm and thickness 2 mm L=150 mm

Net weight:
0.03 Kg

Mounting:
2 4.2x19 mm countersunk screws, with \varnothing 4 countersunk drilling in the lower part of the two beam sections to be connected

Round corner transmission art. SK13

Round corner transmissions are used to connect the two consecutive handrail sections and allow for a change of horizontal or vertical direction.



Material:
aluminium die-cast, alloy EN AB 46100

Geometry:
see figure

Net weight:
0.16 Kg

Mounting:
2 4.2x19mm self-tapping screws on two consecutive sections of the beam

Equipment:
4 \varnothing 4mm countersunk holes (2 bottom and 2 top)

Round cap for fastening art. SK14

Round caps are used to fasten the end of the cross beam to the wall.



Material:

aluminium alloy 6060-T6

Geometry:

round \varnothing 25 mm and thickness 2 mm L=30 mm with closing plate with maximum dimensions 120x70 mm

Net weight:

0.06 Kg

Mounting:

2 \varnothing 12 mm mechanical wall anchors

1 4.2x19 mm countersunk screw, with \varnothing 4 countersunk drilling in the lower part of the cross beam

Equipment:

2 \varnothing 13 holes with wheelbase 90 mm

Polygonal cap art. SK15

Polygonal caps are used to close end of the cross beam.



Material:

aluminium alloy 6060-T6

Geometry:

round \varnothing 25 mm and thickness 2 mm L=30 mm with closing plate with round closing \varnothing 30

Net weight:

0.005 Kg

Mounting:

1 4.2x19 mm countersunk screw, with \varnothing 4 drilling in the lower part of the cross beam

Toe-clip board art. SK16

Used to prevent material from falling when there is no building plenum or it is less than 10 cm.



Material:

aluminium alloy T6-6060

Geometry:

20+150+20 mm thickness 1.5 mm in 3 m rods

Net weight:

0.70 Kg/m

Mounting:

2 4.2x16 countersunk head screws, vertically spaced 80 mm with Ø 4 countersunk drilling on each upright

Toe-clip board support art. SK17

Whenever the toe-clip board is used in the version with floor attachment, this component is interposed between the upright and the toe-clip board to allow for proper mounting.



Material:

aluminium alloy T6-6060

Geometry:

see figure

Net weight:

0.08 Kg

Mounting:

2 4.2x19 mm self-tapping screws for each upright (1 per flat side of the upright)

Equipment:

2 Ø 4 holes

Toe-clip board joint art. SK18

Toe-clip board junctions are used to restore toe-clip board continuity.



Material:

aluminium alloy 2014

Geometry:

130x100 thickness 1.5 mm

Net weight:

0.050 Kg

Mounting:

4 M6x16mm hex head screws with self-locking nut

Equipment:

4 7x25 mm slotted holes

Sign art. CA00

The sign must be posted on every access point to the secured area.

CARTELLO IDENTIFICATIVO OBBLIGATORIO	
<input type="checkbox"/> Punto d'ancoraggio EN 795:2012 -TS16415 Tipo A <input type="checkbox"/> Linea vita orizzontale EN 795:2012 -TS16415 Tipo C <input type="checkbox"/> Binario orizzontale EN 795:2012 EN 795 -TS16415 Tipo D <input type="checkbox"/> Parapetto EN 14122-3:2007 <input type="checkbox"/> Passerella EN 14122-2:2010 <input type="checkbox"/> Binario verticale EN 353-1:2003 <input type="checkbox"/> Scala EN 353-1:2003 <input type="checkbox"/> Linea vita verticale EN 353-1:2003	
Tipo _____ N. massimo di lavoratori connessi _____ Tirante d'aria _____ Piombo n. _____ Data entrata in servizio _____	
Produttori <input type="checkbox"/> Esomaf <input type="checkbox"/> F.I.S.A. <input type="checkbox"/> FALLPROTEC	Installatore _____ _____ _____
Manutenzioni ___/20___ ___/20___ ___/20___ ___/20___ ___/20___	

Material:

PVC

Installation:

with every access

Contents:

type of rail, serial number, date of entry into service of the system, manufacturer name, distributor name, reseller name, installer name

Identifier seal art. C35

Identifier seals are unique for each system and must be positioned at the end of the same. The numbering is the same as reported on the sign described above and in the certification that accompanies the system

Installation:

at the end of each line

Contents:

serial number

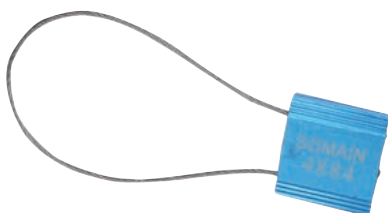

Grub screws

Grub screws are used to fasten the upright bases.



Composition:

flat M6x10mm

Material:

18-8 stainless steel

4.2x19/30 mm self-tapping screw

4.2x19/30 mm self-tapping screws are used to fasten railing extrusions to the railing fitting, joint, corner elements.

Material:

A2 stainless steel

6.3x90 mm self-tapping screw

6.3x90 mm self-tapping hex head screws are used to fasten the concrete counter-weight to the horizontal lever arm.

Material:

A2 stainless steel



4. Assembly

Recommendations: 4.1

Before fitting, a site inspection is recommended to ascertain the real situation of the area on which the system is to be mounted and to check for compliance with the planimetric report of the roof within which all the elements of the system are highlighted.

Installation must be carried out in compliance with the measures for the prevention of accidents in accordance with Legislative Decree 81/2008 - Consolidated Text on Health and Safety and on that indicated by the reference standard EN ISO 14122-3.

Fitters: 4.2

Installation of **Allukemi Sky™** Self-supporting rails includes the training of installers by an in-house technician to put into practice the correct methods for assembly.

The fitters affiliated to the partners of Genesi Italia are obliged to draw up their own Risk Assessment Document (DVR) from which the risks linked to the fitting of the system and the counter-measures adopted to reduce the likelihood of this happening are drawn.

Assembly kit: 4.3

The main work equipment to perform correct installation:

- starter
- bush for 6.3 screw
- PH insert for self-tapping screws
- diameter 3 Allen wrench
- hand tools (pliers, various keys)

Movement and storage: 4.4

Take utmost care during movement and storage of all system components. All the components weigh less than 25 kg, maximum weight allowed for the manual handling of loads by a single operator.

When the weight of the components exceeds this value, movement with two operators or crane must be performed. These operations are also an integral part of the DVR.

Stages: 4.5

The phases described in this chapter are valid for the mounting of the system into the desired position and must be carried out in complete safety, thus complying with the instructions contained in the Safety Operational Plan (SOP) drawn up by the installer, in conformity with the Safety and Coordination Plan (SCP) drawn up by the Safety Coordinator at the Design phase (SCD) or by the Security Coordinator during the Implementation stage (SCI) where these two figures are present.

The steps of installation of this system shall be construed as excluding all those operations that are used to prepare the work area or to access the same.

Upright and lever arm assembly

4.5.1

The first procedure for railing mounting is installation of the upright and the horizontal lever arm on the self-supporting base art. SKA.

Note: position upright bases every 150 cm.

Note: carefully work according to the procedure described below.

- position the upright inside the corresponding housing on the base and screw the two (1 front and 1 rear) M6x10 flat grub screws until the uprights adhere to the base
- position the lever arm inside the corresponding housing on the base and screw in the M6x10 flat grub screw until the tubular adheres to the base

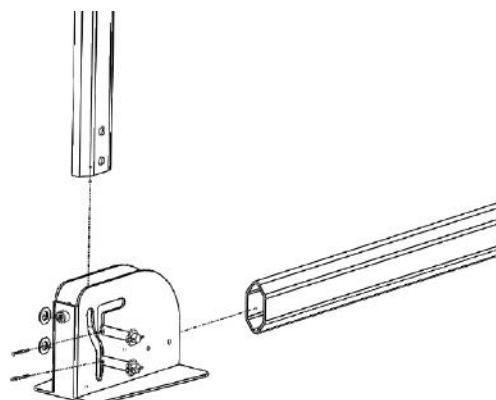
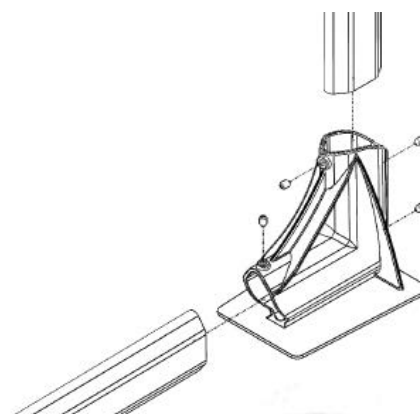

Mounting the concrete counter-weight

4.5.2

A concrete counter-weight art. SKB is mounted to the top of the horizontal lever arm in order to fasten the two components, as follows:

- slip the lever arm into the corresponding hollow area in the concrete counter-weight to end stop (check that the maximum overall dimension of the base block is 120 cm)
- position the SBR rubber for counter-weight art. SKBN under the counter-weight and insert 1 self-tapping 6.3x90 mm hex head screw in the Ø 6.5 mm hole on the top side of the counter-weight.

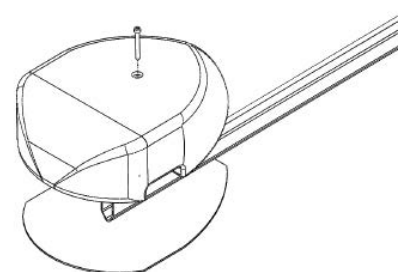

Mounting of polygonal T- and L-fittings and polygonal joints on uprights 4.5.3

As soon as they are installed, polygonal T-fittings art. SK06 should be mounted at the top of middle uprights and polygonal L-fittings art. SK07 should be mounted on end uprights, as follows:

- push the fitting on the upright in order to obtain a total railing height of 110 cm from floor level
- insert 1 4.2x19 self-tapping screw in the Ø 4 countersunk hole positioned on the vertical part of fittings (2 screws per T-fitting art. SK06)

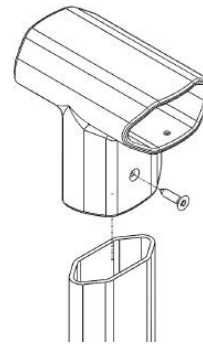

Handrail mounting 4.5.4

- slip the polygonal profile inside the T-fittings and L-fittings seen previously
- fasten it to the polygonal T-fittings and polygonal T-joints, inserting the 2 4.2 x 19 self-tapping screws in the Ø 4 countersunk holes positioned at the bottom horizontal part of the fittings
- fasten it to the polygonal L-fittings, inserting 1 4.2 x 19 self-tapping screw in the Ø 4 countersunk hole positioned at the bottom horizontal part of the fittings

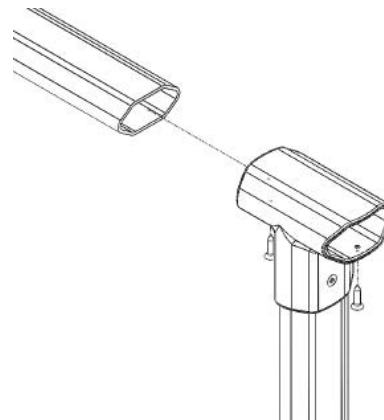

Note: before mounting all fittings, insert polygonal joint art. SK02 to restore handrail continuity as indicated in the corresponding paragraph.

Handrail joint

4.5.5

To restore handrail continuity, insert two consecutive rods of the polygonal joint art. SK02 inside, as follows:

- insert the polygonal joint into half of the first rod
- drill the handrail and the joint at the bottom with 1 Ø 4 countersunk head; insert 1 4.2x19 mm countersunk screw to fasten the two elements
- on the half of the remaining joint, insert the other handrail rod
- drill the handrail and the joint at the bottom with 1 Ø 4 countersunk head; insert 1 4.2x19 mm countersunk screw to fasten the two elements

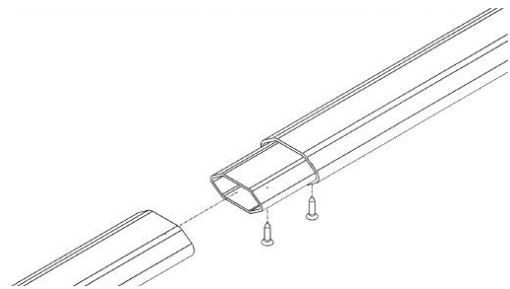

Beam mounting

4.5.6

Whenever plenums are less than 60 cm, a vertical round extrusion upright art. SK11 is inserted to perform the function of a cross beam, as indicated:

- slip the round profile inside the corresponding hole on the uprights
- drill the upright and beam with 1 Ø 4 countersunk hole, insert 1 4.2x30 mm countersunk screw to fasten the two elements

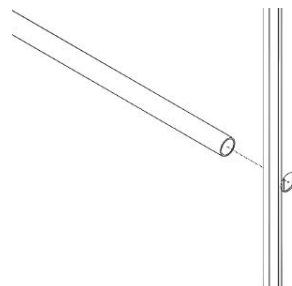

Note: before mounting all the beam, insert round joint art. SK12 to restore handrail continuity as indicated in the corresponding paragraph.

Beam joint

4.5.7

To restore cross beam continuity, insert two consecutive rods of the round joint art. SK12 inside, as follows:

- insert the round joint into half of the first of the rod
- drill the handrail and the joint at the bottom with 1 Ø 4 countersunk hole
- insert 1 4.2x19 mm countersunk screw to fasten the two elements
- on the half of the remaining joint, insert the other cross beam rod
- drill the handrail and the joint at the bottom with 1 Ø 4 countersunk hole
- insert 1 4.2x19 mm countersunk screw to fasten the two elements

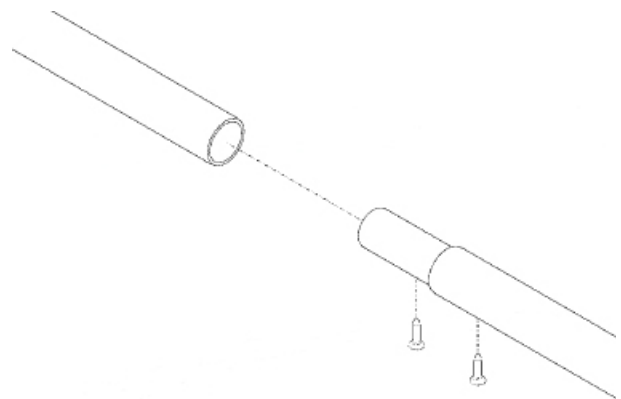

Forming angles on the handrail

4.5.8

Whenever development of the railing requires a change of horizontal direction, insert horizontal polygonal corner transmission art. SK03. If it is necessary to overcome height changes, insert the vertical polygonal corner transmission art. SK04 or horizontal polygonal joint art. SK05 to change horizontal direction with the railing in the inclined configuration. The procedure is the same even with different components:

- insert the handrail 50 mm in the desired element
- insert 1 4.2x19 mm self-tapping screw to fasten the elements
- insert the other handrail in the other end of the element by 50 mm
- insert 1 4.2x19 mm self-tapping screw to fasten the elements

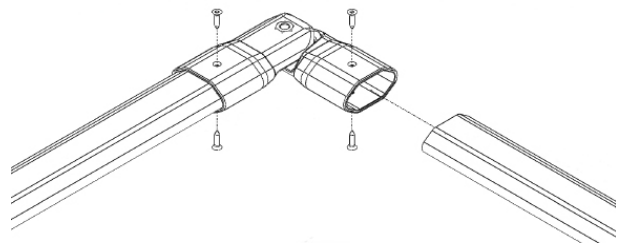

Forming angles on the cross beam

4.5.9

Whenever the development of the rail also involves the cross beam, insert the round corner transmission art. SK13 for both horizontal and vertical direction changes, proceeding as follows:

- insert the cross beam in the corner transmission 30 mm
- insert 1 4.2x19 mm self-tapping screw to fasten the elements
- insert the other cross beam in the other end of the element 30 mm
- insert 1 4.2x19 mm self-tapping screw to fasten the elements

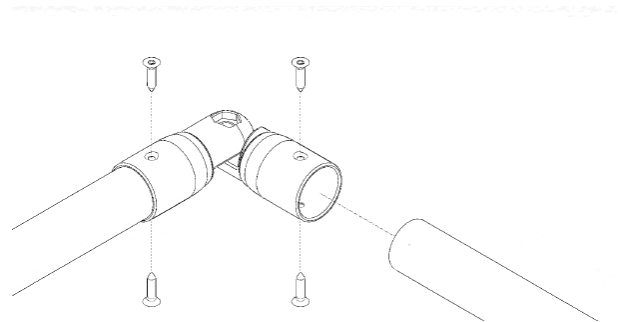

Closing the railing to the wall

4.5.10

Whenever the ends of the railing must be directly mounted to the wall, insert the polygonal cap for fastening art. SK10 on the handrail or the round cap for fastening art. SK14 on the cross beam. The procedure is the same even with different components:

- insert the handrail or cross beam on the corresponding cap until contact is made with the plate
- drill elements at the bottom with 1 \varnothing 4 countersunk hole
- insert 1 4.2x16 mm countersunk screw to fasten the two elements
- drill two \varnothing 14 holes in the wall at a distance of 90 mm (use caps as samples) at a minimum length of 6 cm with a rotopercussion drill
- insert the mechanical anchor and tighten at a torque of 70 Nm

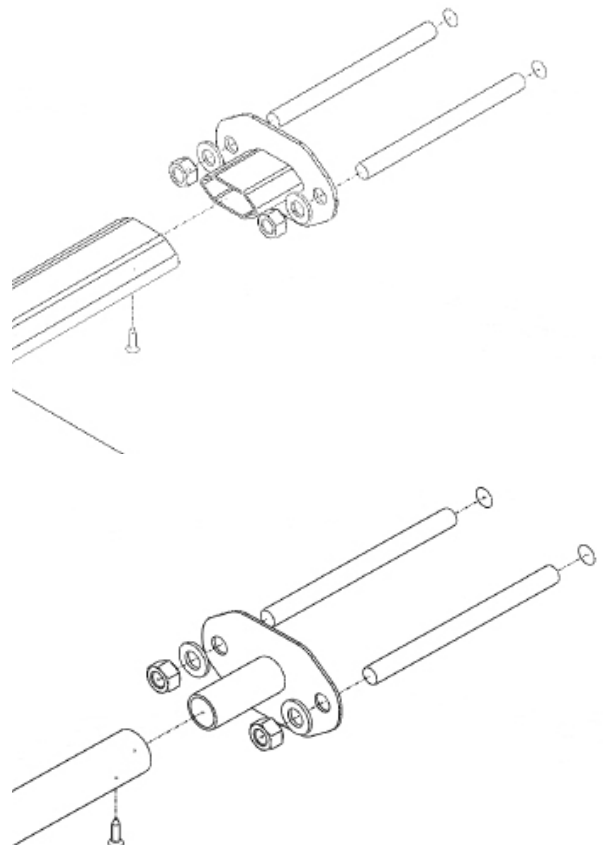

Closing the railing with caps 4.5.11

Whenever the ends of railing remain free (max 50 cm), insert polygonal cap art. SK09 in the handrail or the round cap art. SK15 in the cross beam as follows:

- insert the cap in the handrail or the cross beam until contact is made with the cap plate
- drill elements at the bottom with 1 Ø 4 countersunk hole
- insert 1 4.2x19 mm countersunk screw to fasten the two elements

Toe-clip board installation 4.5.12

In the event that the structure does not have a perimeter plenum, railings are also equipped with a toe-clip board to prevent material from falling over persons, according to the following procedure:

- for each upright, position toe-clip board art. SK17, with the flat side turned inward, using 2 4.2x19 mm countersunk screws (1 per upright side) with Ø 4 drilling
- position the board with wings turned outward
- drill the board and the support with 1 Ø 4 countersunk hole
- insert 1 4.2x19 mm countersunk screw to fasten the toe-clip board to the support

Toe-clip board joint 4.5.13

To restore toe-clip board continuity, insert two consecutive rods of the toe-clip board joint art. SK18 as follows:

- drill the toe-clip board according to the joint template with 4 Ø 7 holes (2 for each rod)
- insert 2 M6x16 hex head screws per side and fasten relative self-locking nuts to end stop on the toe-clip board without tightening to allow at least 1 cm of sliding on the joint

System sealing

4.5.14

Sealing of the line consists of positioning the tamper-proof seal with the identifier seal art. C35 in the following manner:

- insert the identifier seal at the railing access point

Sign installation

4.5.15

Closing of assembly is completed with installation of the sign art. CA00, mandatory at each access point, displaying the information described above.

CARTELLO IDENTIFICATIVO OBBLIGATORIO	
<input type="checkbox"/> Punto d'ancoraggio EN 795:2012 -TS16415 Tipo A <input type="checkbox"/> Linea vita orizzontale EN 795:2012 -TS16415 Tipo C <input type="checkbox"/> Binario orizzontale EN 795:2012 EN 795 -TS16415 Tipo D <input type="checkbox"/> Parapetto EN 14122-3:2007 <input type="checkbox"/> Passerella EN 14122-2:2010 <input type="checkbox"/> Binario verticale EN 353-1:2003 <input type="checkbox"/> Scala EN 353-1:2003 <input type="checkbox"/> Linea vita verticale EN 353-1:2003	
Tipo _____ N. massimo di lavoratori connessi _____ Tirante d'aria _____ Piombo n. _____ Data entrata in servizio _____	
Produttori <input type="checkbox"/>  <input type="checkbox"/>  <input type="checkbox"/> 	Installatore
Manutenzioni ___/20___ ___/20___ ___/20___ ___/20___ ___/20___	

8. Guarantees

Duration 6.1

A 10 year guarantee is given from the date of the delivery note on all stainless steel pieces making up the **Allukemi Sky™ Self-supporting** system.

- by the adding to our systems of parts produced by the buyer or from other sources other than Genesi Italia.
- by an event of force majeure or any event outside the control of the seller such as wars, lightning, etc.

Exclusion 6.2

The guarantee will only be granted if:
the material was installed and has been used in accordance with the installation instructions and the technical instructions of Genesi Italia.

- The guarantee will not be granted in cases where:**
- the products are made from galvanised or zinc plated steel
 - safety products include parts or accessories of external origin
 - in this case the agreed guarantee will be that of the supplier of the above parts

- The guarantee is excluded when the defect is caused:**
- by an intervention or a change made to the original system without the written permission of the manufacturer/distributor
 - by use that is irregular or that does not conform to the intended use of the equipment
 - by defective installation not in compliance with drawings or performed to code
 - by a client's failure to communicate special conditions (pollution, temperature, number of users, etc.) regarding equipment use
 - by an underestimation of support resistance generating the destruction or non-compliance of our equipment

Limitations 6.3

In all cases our guarantee is limited to the replacement or repair of elements or equipment that are formally recognised as defective by our technical service. If the repair is entrusted to a third party, this can only be performed after acceptance by Genesi Italia of the repair quote.

Any returning of equipment must be undertaken with the consent of Genesi Italia.

The guarantee only applies to elements returned and as such does not include the costs of removal and re-installation of the equipment in the group in which it is integrated.

The repair, replacement or modification of parts or equipment during the guarantee period can determine extension of the guarantee.

Responsibility

6.4

Genesi Italia will be responsible, under the conditions of common law, for the material damage caused by your equipment or by your personnel.

Repair of the material damage attributable to the seller is expressly limited to a sum that does not exceed the value of the equipment involved, subject of the order.

By express convention, the seller and the customer mutually waive requiring the repair of the indirect and intangible damage of any kind, such as operating losses, loss of earnings, costs of delay, reminder, removal and reinstallation of the equipment, loss of future contracts, etc.

Renewal

6.5

This guarantee of 10 years may be renewed at the request of the customer, after a technical inspection carried out, upon payment, by our services of the equipment installed.

Testing and maintenance

6.6

As far as possible, before each use, perform a visual examination of the components of the system.

In case of doubt, ask the installing company or a maintenance engineer, authorised and responsible for this type of intervention, for an inspection.

Allukemi Sky™ Self-supporting systems do not require maintenance. Should this be deemed necessary there is the option of this annual maintenance being performed by one of our staff authorised and qualified for this type of intervention.

In the event of a fall the system shall be the subject of necessary maintenance by a competent and qualified technician for this type of operation.

Jurisdiction

6.7

The applicable law is Italian legislation and the place of jurisdiction is in Bergamo (Italy) that will have exclusive jurisdiction over any dispute arising out of, or in some way related to, the products covered by this Manufacturer's Instructions.

7. References.

Manufacturer's Instructions 7.1

Manufacturer's Instructions - Maintenance

Regulations 7.2

Technical standards 7.2.1

EN ISO 14122-3:2010

Permanent means of access to machinery – Safety of machinery – Stairs, stepladders, railings.

National regulations 7.2.2

Legislative decree 81/2008 and subsequent additions and modifications

Consolidated text on health & safety

Local regulations 7.2.3

Circ. 4 /SAN/2004 of the Lombardy Region

Update of Title III of the Local Regulations of Hygiene, transposition of the integration to Title III of the Regional Hygiene Law drawn up by the ASL of Bergamo

Decree of the President of the Regional Executive no. 62 of 23.11.2005 of the Region of Tuscany

Implementing regulation of art. 82, paragraph 16 of Regional Law no. 1 of the 03.01.2005 relating to the technical instructions on preventive and protective measures for the access, transit and execution of works at height in conditions of safety

Decree of the president of the province no. 7-114/ Leg. of 25.02.2008 of the Province of Trento

Technical regulations for the prevention of accidents as a result of falls from heights during routine maintenance on roofs

Decree of the Regional Government no. 2774 of 22.09.2009 in the Region of Veneto

Technical instructions on preventive and protective measures to be implemented in buildings for the access, transit and execution of maintenance works at height in conditions of safety

Regional law no. 5 of 15.02.2010 of the Region of Liguria

Rules for the prevention of falls from heights on construction sites.

Decree of the Regional Government no. 1284 of 28.10.2011 in the Region of Umbria

Approval guidelines for the prevention of falls from heights

Internet sites 7.3

www.Genesiitalia.it

Official site of the exclusive distributing company

www.uni.com

Italian national site of unification

8. Manufacturer and Distributor.

Manufacturer

8.1

Fisa srl
via Donizetti, 109/111
24030 - Brembate di Sopra - Bg

Distributor

8.2

Genesi Italia
via Donizetti, 109/111
24030 - Brembate di Sopra - Bg



Genesi Italia

Via Donizetti, 109/111
24030 Brembate di Sopra
Bergamo - Italy

T. +39 035 0332049
F. +39 035 6220438
info@genesibesafe.com



genesibesafe.com

Genesi Italia, Be Safe